

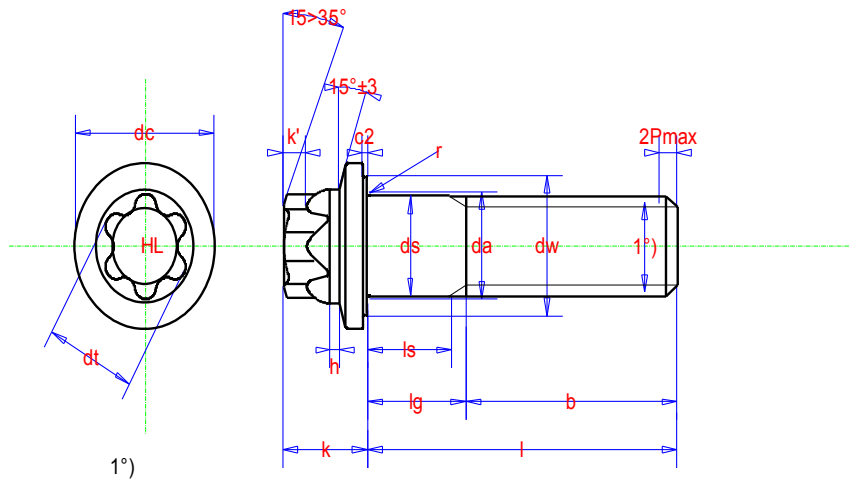

Address
Country
Other

Report n°: _____ of _____ 14/12/05 17:44
tested by _____
Supplier _____ Lot _____



d
d2
d3

DIN 34801 M10x1.50x100 - 8.8

Symbol	max.	min.	Sample 1	Sample 2	Sample 3	Sample 4	Sample 5	Gauge
l	100							
c1	3.9	3.6						
c2	0.6							
da	11.2							Profil
dc	21.8							
dt	12.65							
dw		19.6						Profil
h	1.3							
k	12	11.75						
k'		3.7						
r		0.4						
hl	E14							
b	83	80						
ds	10	9.78						
lg	20							
ls		12.5						
d3	8.128	7.938						Caliber
d2	8.994	8.862						Caliber
d	9.968	9.732						micrometer

Comment